

2910

RF Vector Signal Generator

- Exceptional signal generation capability at an economical price
- Fast signal tuning for faster test execution—<1ms for most signals
- Continuous frequency range of 400MHz–2.5GHz spans key mobile wireless frequency bands
- Intuitive, easy-to-use graphical user interface
- 40MHz modulation bandwidth using internally generated modulation
- >100MHz modulation bandwidth using external I/Q inputs
- Built-in waveforms for popular digital (GSM/GPRS/EDGE, cdmaOne/cdma2000 1xRTT, and WCDMA) and analog (CW, AM, FM, Φ M, noise, two-tone CW, and pulsed) signal formats
- GUI supports editing waveform files and creating new ones for GSM, GPRS, EDGE, WCDMA, cdmaOne, and cdma2000 downlink signals
- 256MB (64 mega-samples) built-in arbitrary waveform generator supports downloading waveforms generated externally
- Half-rack, 3U enclosure fits easily into both rack and benchtop system configurations
- Remote control via Ethernet, USB, and GPIB interfaces
- Readily updatable software-defined radio architecture



The Model 2910 RF Vector Signal Generator is the first in a series of Keithley RF instruments that sets a new performance standard. It's priced significantly less than instruments or systems with comparable levels of functions and performance and offers far more functionality and better performance than comparably priced equipment. While the Model 2910 offers capabilities and ranges that make it ideal for production testing of today's sophisticated mobile handsets, it also has features that make it useful for applications like testing mobile communications infrastructure, RFICs, and wireless connectivity devices. The Model 2910's exceptional testing capabilities and ease of use make it a good choice for use in mobile communications research and education settings.

When characterizing or verifying DUT performance, the speed of the RF signal generator can have a major impact on overall test throughput and, therefore, the cost of test. Higher speed also makes it possible for manufacturers to respond quickly to increased volume demands. The Model 2910 is designed to execute key tasks like frequency tuning, amplitude switching, and waveform changes significantly faster than other products available.

The Model 2910's continuous frequency range of 400MHz to 2.5GHz spans key mobile wireless bands. Digital waveforms for key tests in major cellular formats (GSM, GPRS, EDGE, WCDMA, cdmaOne, cdma2000) for testing handsets are built in, as is support for analog modulation (continuous wave, two-tone continuous wave, amplitude modulation, frequency modulation, phase modulation, pulse modulation, and noise). The 64 mega-sample Arbitrary Waveform Generator (ARB) and 40MHz modulation bandwidth support downloading a wide range of externally generated signal waveforms. A 2MHz noise bandwidth supports "quick-check" noise immunity tests on a variety of devices.

The instrument's software-defined radio architecture gives telecom manufacturers the testing flexibility needed to keep pace with changing wireless technologies, as well as fast frequency tuning and amplitude settling. New signal structures and instrument features can be incorporated easily and economically with ongoing firmware updates.

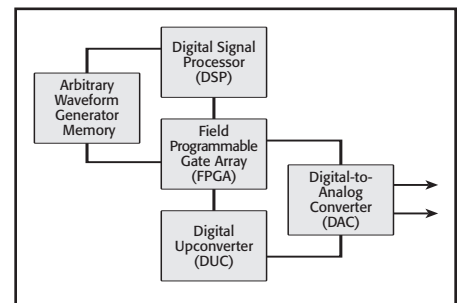

Figure 1. The Model 2910's software-defined radio architecture allows manufacturers to adapt it readily to changing test requirements.

Signal generator for mobile communications testing

RF/MICROWAVE SWITCH & INST.

1.888.KEITHLEY (U.S. only)

www.keithley.com

KEITHLEY

A GREATER MEASURE OF CONFIDENCE

2910

Ordering Information

- 2910-FRK RF Connector on Front, Configured for Rack Installation***
- 2910-RRK RF Connector on Rear, Configured for Rack Installation***
- 2910-F RF Connector on Front, Configured for Bench-top Use****
- 2910-R RF Connector on Rear, Configured for Bench-top Use****

* Versions configured for rack installation include rack mount kit and exclude bumpers and handle.

** Versions configured for bench-top use include bumpers and handle and exclude rack mount kit.

Options

- 2910-ARB 64 Mega-Sample Arbitrary Waveform Generator**
- 2910-GSM GSM Signal Generation Personality**
- 2910-CDMA2000 cdma2000 Signal Generation Personality**
- 2910-WCDMA WCDMA Signal Generation Personality**
- 2910-LPN Low Phase Noise**

RF Vector Signal Generator

Higher Speed for Lower Cost of Test

A state-of-the-art digital signal processor (DSP) and high speed RF architecture provide the Model 2910's speed and help reduce handset manufacturers' cost of test:

- **Faster tuning.** The Model 2910 can switch frequencies in less than one millisecond for most frequency steps, which is significantly faster than many higher-priced competitive instruments.
- **Faster amplitude settling.** When changing signal amplitude levels, the Model 2910's unique RF output structure typically settles to specified level accuracy in less than three milliseconds, which is significantly faster than most competitive instruments.
- **Highly responsive controls.** The Model 2910's high speed response to user inputs from the front panel or to programmed commands ensure fast waveform downloads and fast switching from one waveform to another, eliminating waiting times.
- **Large Arbitrary Waveform Generator.** A built-in Arbitrary Waveform Generator (AWG) with 256MB (64 mega-samples) of waveform memory allows users to have many waveforms resident in memory simultaneously. The large memory supports downloading ARB files created with external software packages like MATLAB®, Mathcad®, or other tools capable of generating I/Q waveforms. A choice of hardware triggering (for maximum speed) and software triggering (for simplified command programming) makes it easy to switch quickly between waveforms—typically in less than three milliseconds.

Powerful Built-in Tools and Capabilities

The most important digital signal structures needed to produce forward link (downlink) signals for all the major cellular formats (GSM, GPRS, EDGE, WCDMA, cdmaOne, cdma2000) are already built in to the Model 2910. The intuitive graphical user interface (GUI) greatly simplifies generation of non-standard signals or modification of existing waveforms for GSM, GPRS, EDGE, WCDMA, cdmaOne, and cdma2000 forward link (downlink) signals. The large arbitrary waveform generator memory and 40MHz of modulation bandwidth extend the signal generation capability to virtually any signal with up to 40MHz of bandwidth. For applications that require even more modulation bandwidth, the Model 2910 gives users the external I/Q modulation inputs (with >100MHz of modulation bandwidth).

The Model 2910's continuous tuning capability from 400MHz–2.5GHz covers all the key mobile communications bands, but also expands its applications far beyond the production test floor. The user-friendly GUI, easy-to-use front panel controls, and range of analog modulation capabilities make it an equally good choice for R&D applications.

Superior Signal Generation Accuracy

Digital baseband processing and optimal real-time digital reconstruction filtering allow the Model 2910 to deliver an extremely clean signal to a high performance I/Q modulator. As a result, the modulator produces signals with outstanding modulation quality. For example, the error vector magnitude (EVM) for EDGE signals is extremely low (<0.5%). This ensures precise, repeatable signals that help minimize measurement errors.

Outstanding amplitude accuracy (<0.5dB) and linearity (<0.05dB) minimize signal level uncertainty, which minimizes measurement errors, simplifies the testing process, and allows for tighter specifications for devices under test.

APPLICATIONS

- **Mobile handset production test**
- **Handset R&D and design verification**
- **Testing mobile communications infrastructure**
- **RFIC testing**
- **Wireless connectivity testing (802.11b/g WLAN, Bluetooth)**
- **Research and education in mobile communications**

1.888.KEITHLEY (U.S. only)

www.keithley.com

KEITHLEY

A GREATER MEASURE OF CONFIDENCE

Easy to Configure, Easy to Use

A variety of features combine to simplify configuring and operating Model 2900-based RF test systems:

- **Intuitive GUI.** The simplicity of the Model 2910's touch-screen graphical user interface makes it ideal for both experienced RF test engineers and novices such as students.
- **Compact size.** At just 3U (5.25 inches) high and half the width of a 19-inch rack, the Model 2910 is equally well-suited for test rack installation and benchtop use. Its compact enclosure makes it easy to pair with complementary half-rack RF instruments for a lot of testing capability in little space.
- **Choice of remote programming interfaces.** The Model 2910 offers wide connection flexibility when linking it to a system controller. Its built-in 100Base-T Ethernet and USB interfaces allow direct, high speed programming and command transfer. A GPIB interface is also included for use in legacy environments.
- **Flexible remote software tools.** A collection of tools are included with the Model 2910 to provide flexibility and simplicity to developers of remote control software applications. Programmers can develop applications directly in SCPI or make use of IVI-COM and IVI-C drivers, or a suite of LabVIEW™ building blocks.
- **LXI Class C Compliance.** The Model 2910 supports the physical, programmatic, LAN, and web portions of the emerging LAN eXtensions for Instrumentation (LXI) standard.
- **Graphical Help system.** The comprehensive and easy-to-use documentation in the instrument's Help system is accessible both through the GUI and off-line, so users can refer to it while working directly with the Model 2910 or while working at their desks on their PCs.

Keithley's Growing RF Line

The Model 2910 is the latest addition to our expanding RF/wireless test offering. In fact, Keithley serves many stages within the wireless industry, starting with our automated DC/RF parametric test systems for wafer-level testing. Component manufacturers often choose Series 2400 and 2600 SourceMeter® instruments for high speed DC testing of packaged parts like RFICs. Keithley's high speed power supplies and battery/charger simulators are widely used in board-level handset testing and our THD Multimeters and Audio Analyzing DMMs are popular choices for audio test systems. We also have a broad array of RF/microwave signal routing solutions, in both standard and custom configurations, ranging from stand-alone switches and simple plug-in modules for multimeters to fully integrated turnkey solutions designed for production test applications.



Figure 2. The Model 2910 features an intuitive GUI that simplifies selecting, creating, or editing a variety of waveforms.

Key Specifications

FREQUENCY RANGE: 400MHz to 2.5GHz.
 AMPLITUDE RANGE (CW): -120dBm to +13dBm.
 ABSOLUTE AMPLITUDE LEVEL ACCURACY: ± 0.5 dB (typically $< \pm 0.3$ dB).
 TUNING SPEED: < 3 ms (typically < 1 ms).
 INTERNAL MODULATION BANDWIDTH: 40MHz
 ARBITRARY WAVEFORM MEMORY: 64 mega-samples [256MB (16-bit I and Q)].

For additional information on the Model 2910 and complete specifications, visit our website at www.keithley.com



Figure 3. The Model 2910 rear panel.

1.888.KEITHLEY (U.S. only)

www.keithley.com

KEITHLEY

A GREATER MEASURE OF CONFIDENCE

Specifications are subject to change without notice.
All Keithley trademarks and trade names are the property of Keithley Instruments, Inc.
All other trademarks and trade names are the property of their respective companies.

KEITHLEY

A G R E A T E R M E A S U R E O F C O N F I D E N C E

KEITHLEY INSTRUMENTS, INC. ■ 28775 AURORA ROAD ■ CLEVELAND, OHIO 44139-1891 ■ 440-248-0400 ■ Fax: 440-248-6168 ■ 1-888-KEITHLEY ■ www.keithley.com

BELGIUM

Sint-Pieters-Leeuw
Ph: 32-2363-0040
Fax: 32-2363-0064
www.keithley.nl

UNITED KINGDOM

Theale
Ph: 44-118-929-7500
Fax: 44-118-929-7519
www.keithley.co.uk

MALAYSIA

Kuala Lumpur
Ph: 60-3-4041-0899
Fax: 60-3-4042-0899
www.keithley.com

CHINA

Beijing
Ph: 8610-82255010
Fax: 8610-82255018
www.keithley.com.cn

INDIA

Bangalore
Ph: 91-80-2212-8027
Fax: 91-80-2212-8005
www.keithley.com

NETHERLANDS

Gorinchem
Ph: 31-1-836-35333
Fax: 31-1-836-30821
www.keithley.nl

FINLAND

Espoo
Ph: 358 9 88171661
Fax: 358 9 88171662
www.keithley.com

ITALY

Milano
Ph: 39-02-55 38 421
Fax: 39-02-55 38 42 28
www.keithley.it

SINGAPORE

Singapore
Ph: 65-6747-9077
Fax: 65-6747-2991
www.keithley.com.sg

FRANCE

Saint-Aubin
Ph: 33-1-6453-2020
Fax: 33-1-60-1-77-26
www.keithley.fr

JAPAN

Tokyo
Ph: 81-3-5733-7555
Fax: 81-3-5733-7556
www.keithley.jp

SWEDEN

Solna
Ph: 46-8-509-04-600
Fax: 46-8-655-26-10
www.keithley.com

GERMANY

Germering
Ph: 49-89-84-93-070
Fax: 49-89-84-93-0734
www.keithley.de

KOREA

Seoul
Ph: 82-2-574-7778
Fax: 82-2-574-7838
www.keithley.co.kr

TAIWAN

Hsinchu
Ph: 886-3-572-9077
Fax: 886-3-572-9031
www.keithley.com.tw